

PLAN VIEW

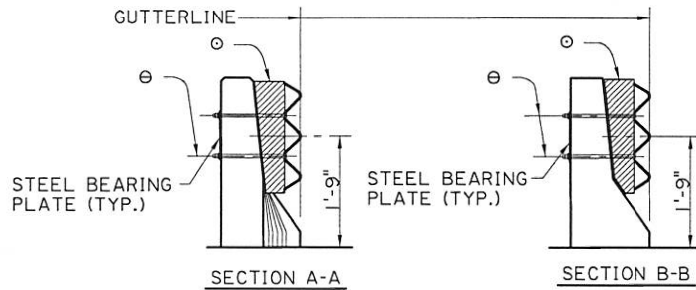

- ⊙ 2 - 5/8" ⌀ BUTTON HEAD BOLTS WITH 5/8" BEARING PLATE, NUTS, & WASHERS (TYP.)
- ⊙ 6" X 8" X 1'-10" TREATED TIMBER BLOCK (CUT & SHAPE IN THE FIELD TO FIT).

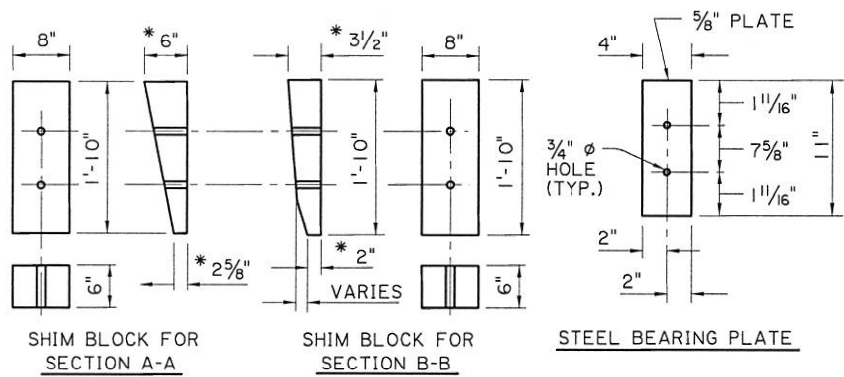

NOTES:

1. FOR ADDITIONAL INFORMATION ON GUARD RAIL TRANSITION, SEE STANDARD PLANS FOR HIGHWAY GUARD RAIL (MASH), SHEET 3 OF 11.
2. ALL HARDWARE AND TIMBER USED FOR CONNECTING THE SINGLE THRIE BEAM TO THE EXISTING BRIDGE RAIL SHALL BE PAID FOR UNDER ITEM 704-01-01020, GUARD RAIL (SINGLE THRIE BEAM), (6'-3" POST SPACING) PER LIN. FT.
3. ANY DAMAGE DONE TO THE EXISTING STRUCTURE DURING INSTALLATION OF THE GUARD RAIL SHALL BE REPAIRED AT THE CONTRACTORS EXPENSE AND TO THE SATISFACTION OF THE PROJECT ENGINEER.
4. GALV. STEEL Ogee WASHER MAY BE USED IN LIEU OF THE STEEL BEARING PLATE.
5. ALL 5/8" ⌀ BOLTS SHALL BE ASTM A307.
6. A 25'-0" SECTION OF GUARD RAIL (WITH NO SPLICE) SHALL BE INSTALLED SYMMETRICALLY WITH RESPECT TO THE SECOND POST ON EACH END OF THE STRUCTURE.
7. THE WOOD SHIM BLOCKS SHALL BE CUT & SHAPED IN THE FIELD TO FIT THE LOCATION WITH A SNUG FIT.
8. THE BOLT HOLES SHALL BE FIELD DRILLED THRU THE GUARD RAIL, SHIM BLOCKS AND THE BARRIER RAIL AT THE SAME TIME.
9. THE GUARD RAIL SHALL NOT PROTRUDE BEYOND THE GUTTER LINE.

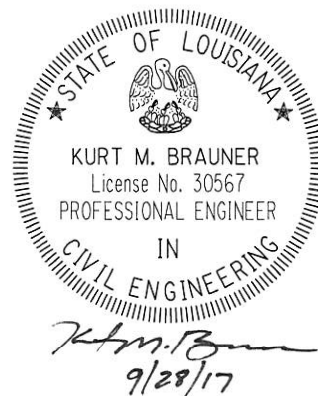

* DIMENSIONS ARE ASSUMED. ADJUST IN THE FIELD AS REQUIRED. HOLES SHALL BE DRILLED IN THE FIELD. SEE NOTE NO. 8.

BRIDGE AND STRUCTURAL DESIGN	<p>NEW JERSEY BARRIER RAIL RETROFIT FOR STRUCTURES LESS THAN 60 FT. FOR USE WITH HIGHWAY GUARD RAIL (MASH)</p> <p>B.D.2.6.5.1.08</p>	<p>STATE OF LOUISIANA KURT M. BRAUNER License No. 30567 PROFESSIONAL ENGINEER IN CIVIL ENGINEERING</p> <p><i>K.M. Brauner</i> 9/28/17</p>	DESIGNED	P. FOSSIER	PARISH		SHEET NUMBER
			CHECKED	K. BRAUNER	CONTROL SECTION		
			DETAILED	J. DOUCET	STATE PROJECT		
			CHECKED	P. FOSSIER			
			REVIEWED	C. GUIDRY			
			SERIES #				
			NO.	DATE	REVISION OR CHANGE ORDER DESCRIPTION	BY	